

Installation Instructions

*P/N 1-960446-01
Edition 2
September 1998*

EasyCoder 601 XP Label-Taken Sensor

 **ntermec**

A **UNOVA** Company

Description

The Label-Taken Sensor (LTS) is an optional device, which enables the printer's firmware to detect if the latest printed label, ticket, tag etc. has been removed before printing another copy.

The label-taken sensor is usually factory-fitted, but it is also available as a kit for upgrading of existing printers by an authorized service technician. It cannot be fitted in combination with a paper cutter.

The label-taken sensor consists of a photoelectric sensor with a bracket and a connection cable. The sensor is fitted inside the front hatch, see illustration below.

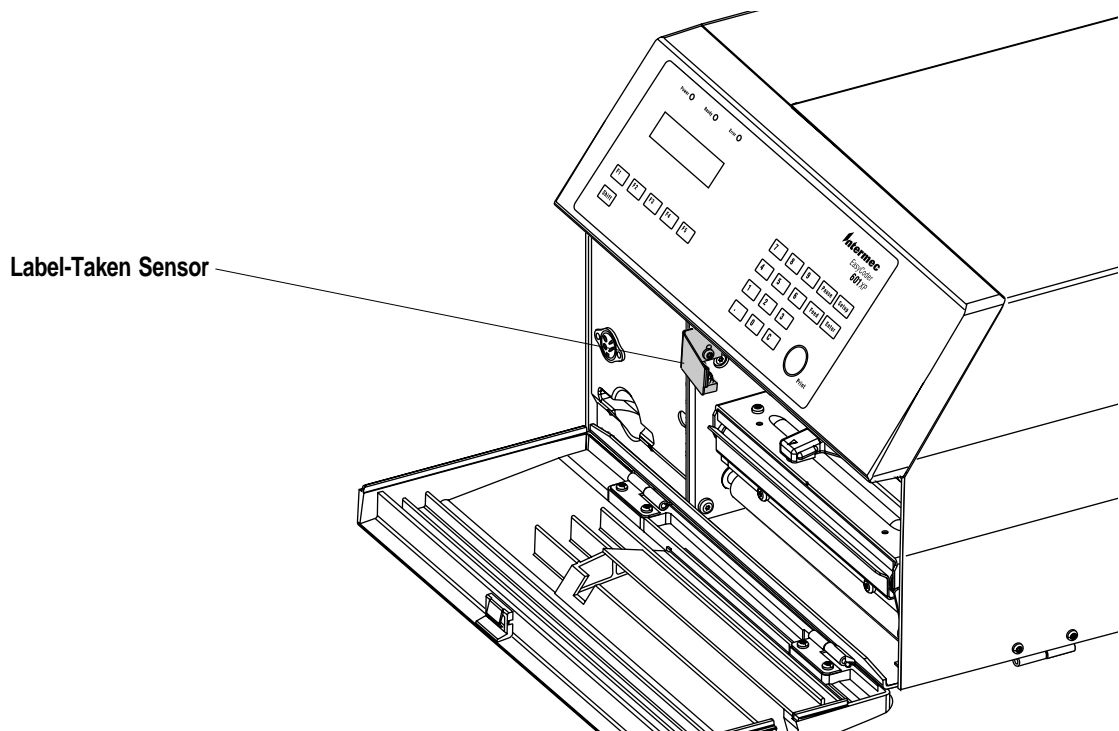

The photoelectric sensor emits a narrow beam of light, which will be reflected back to the sensor by any label, ticket, tag, piece of strip or backing paper, that has not been removed from the outfeed area. A prerequisite is that the web is fed out along the inner wall of the printer.

The LTS is connected to **P51** on the CPU board. The sensitivity of the receiver can be adjusted by means of the potentiometer **WR51** and the intensity of the emitter by a strap on **P55** on the CPU board.

The point of detection of the LTS is situated 10 mm (0.39") outside the inner edge of the paper web and 22 mm (0.87") in front of the dot line on the printhead.

Vertical detection range is adjustable from 5 mm (0.2") above the edge of the tear-off/dispenser edge to max. 50 mm (2") below the edge (with strap fitted on P55).

*EasyCoder 601 XP
Label-Taken Sensor
Installation Instructions
Edition 2, September 1998
Part No. 1-960446-01*

Installation

The Label-Taken Sensor Kit consists of:

- One Reflecting Sensor assy. with cable and connector
- One Sensor Bracket
- One Screw
- One Installation Instructions booklet

The only tools needed are the combi Torx screwdriver delivered with the printer and a small non-conductive flat-tipped screwdriver.

The LTS must either be enabled by means of an LTS& ON statement, or the status of the LTS has to be polled in the UBI Fingerprint program by means of the PRSTAT function, as otherwise the printer will not react on the LTS signal.

- Make a simple program that checks the printer's status, e.g.:

```

10  BREAK 1,88
20  BREAK 1 ON
30  ON BREAK 1 GOSUB 1000
40  FORMFEED
50  IF (PRSTAT AND 2) THEN BEEP
60  GOTO 50
70  END
1000 BREAK 1 OFF
1010 GOTO 70
RUN

```

You can break this program by transmitting the character X (ASCII 88 decimal) on the standard serial interface "uart1".

- **CAUTION!**
Turn off the power. For double security, pull the power cord out of the mains receptacle at the rear plate of the printer.
- Open the right-hand door and the front hatch, and remove the left-hand cover.
- In not already done before delivery, press the reflecting sensor assy. into the bracket as illustrated below.

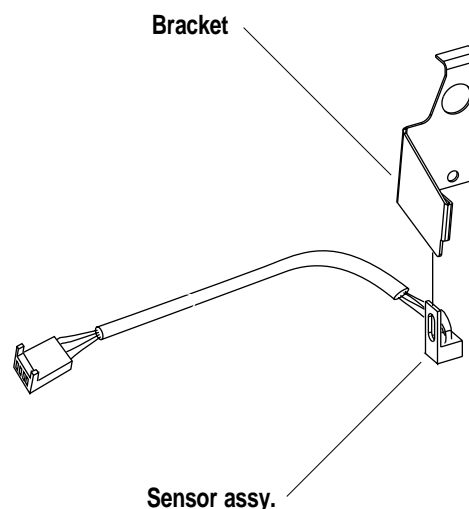

Installation, cont'd.

- Using the screw included in the kit, fit the sensor/bracket assembly to the inner wall of the print unit as shown by the two illustrations below. Fit the cable underneath the top part of the bracket, as illustrated in the lowermost picture.

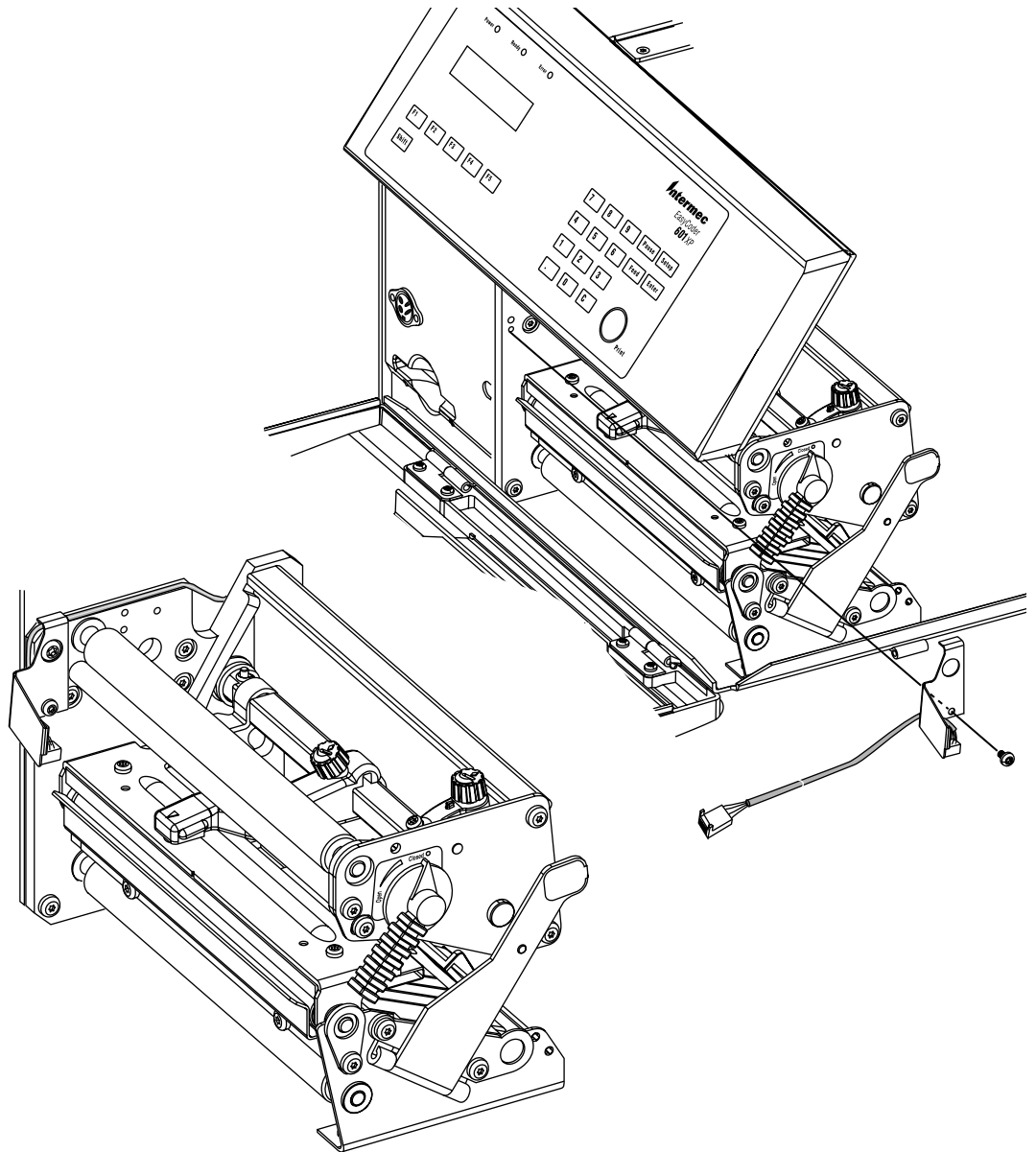

- Slip the cable of the label-taken sensor through the hole in the centre-line wall of the printer into the electronics compartment.
- Connect the cable to **P51** on the CPU board. Be careful so the cable does not interfere with any moving mechanical parts.
- Insert the power cord and turn on the power.

CAUTION!

The electronics compartment contains high voltage wires and components.

Use a non-conductive screwdriver to avoid the risk of causing a short-circuit!

Adjustments

Adjust the sensitivity of the label-taken sensor by means of the potentiometer **WR51** (marked “LTS”) on the CPU board:

- Start up Intermec Fingerprint and run the program described on page 2. Leave the label in the outfeed slot to create a label-not-taken condition.
- The printer should start to beep continuously. If not, turn the potentiometer back and forth until the beeping starts.
- Adjust the potentiometer **WR51** so the beeping does not stop when the screw is turned a quarter of a turn in either direction.
- If necessary, fit or remove a jumper on **P55** to change the intensity of the LTS emitter:
Jumper fitted = Higher intensity
Jumper removed = Lower intensity
- Remove the label. The beeping should cease immediately.
- If necessary, readjust the potentiometer and/or change the strap on **P55**.
- Break the program by typing **X** on the host.

When the label-taken sensor works properly, put back the left-hand cover and close the front hatch and right-hand door. Then the printer is ready for operation.

Information in this manual is subject to change without prior notice and does not represent a commitment on the part of Intermec Printer AB.

© Copyright Intermec PTC AB 1998. All rights reserved. Published in Sweden.

*EasyCoder is a trademark of Intermec Technologies Corp.
Torx is a registered trademark of Camcar Division of Textron Inc.*