

**Compact Keyboard Instructions**

Use these instructions to install the appropriate keyboard overlay on the Compact Keyboard (Model AK4) for the CV30 Fixed Mount Computer. The shipping box for the compact keyboard contains these items:

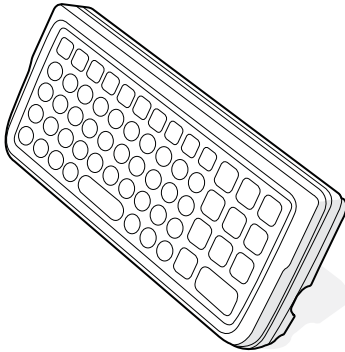

Compact keyboard

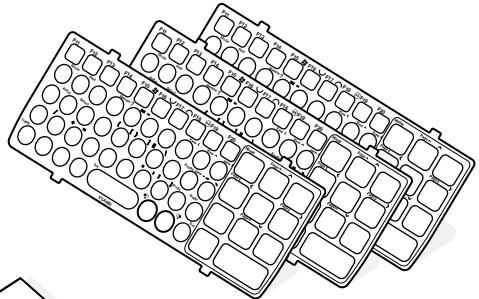

Three keyboard overlays

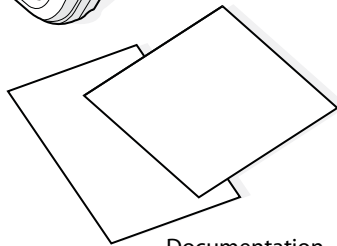

Documentation

The keyboard overlays included with the compact keyboard include:

- Standard keyboard overlay
- 3270-5250 keyboard overlay
- VT-ANSI keyboard overlay

**To install the keyboard overlay**

- 1 Insert the tabs on the top of the keyboard overlay into the corresponding slots in the compact keyboard.

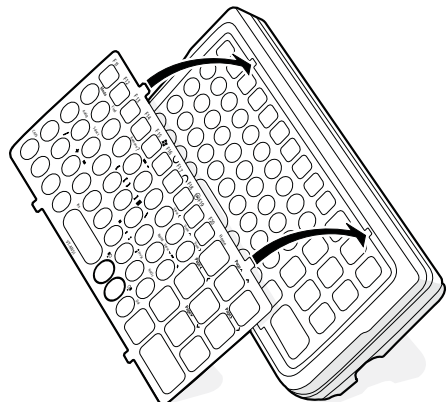

- 
- 2 Insert the bottom two tabs on the keyboard overlay into the corresponding slots on the compact keyboard.



- 3 Attach the keyboard cable to the USB port on the CV30. (This illustration includes the compact keyboard mounting kit for illustration purposes only.)

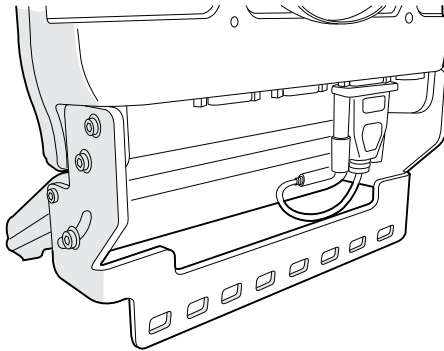

Electrical rating:  5V, 500 mA



Caution

See Compliance Insert for use restrictions associated with this product.

CV30 Compact Keyboard Instructions



P/N 943-087-002

**Intermec**

**Worldwide Headquarters**  
6001 36th Avenue West  
Everett, Washington 98203  
U.S.A.

**tel** 425.348.2600

**fax** 425.355.9551

[www.intermec.com](http://www.intermec.com)

© 2007 Intermec Technologies Corporation. All rights reserved.