



Intermec



User's Guide

**Sabre 1552 Bar
Code Scanner**

Intermec Technologies Corporation
6001 36th Avenue West
Everett, WA 98203

U.S. service and technical support: 1-800-755-5505
U.S. media supplies ordering information: 1-800-227-9947

Canadian service and technical support: 1-800-668-7043
Canadian media supplies ordering information: 1-800-268-6936

Outside U.S.A and Canada: Contact your local Intermec service supplier.

The information contained herein is proprietary and is provided solely for the purpose of allowing customers to operate and/or service Intermec manufactured equipment and is not to be released, reproduced, or used for any other purpose without the written permission of Intermec.

Information and specifications in this manual are subject to change without notice.

© 2002 by Intermec Technologies Corporation
All Rights Reserved

The word Intermec, the Intermec logo, INCA (under license), MobileLAN, JANUS, IRL, Trakker Antares, EZBuilder, TE 2000, Data Collection Browser, dcBrowser, Universal Access Point, UAP, Duratherm, EasyCoder, Precision Print, PrintSet, Virtual Wedge, and CrossBar are either trademarks or registered trademarks of Intermec.

Throughout this manual, trademarked names may be used. Rather than put a trademark (™ or ®) symbol in every occurrence of a trademarked name, we state that we are using the names only in an editorial fashion, and to the benefit of the trademark owner, with no intention of infringement.

Contents

Overview of the Sabre 1552 Scanner 5

Unpacking the Scanner 7

Understanding the Features 8

Light 8

Beeps 9

Electrical Rating 9

***Associating the Scanner to the MicroBar 9745 Base
Station 10***

Operating the Scanner 11

Configuring the Marker Beam 13

Troubleshooting the Scanner 14

Maintaining the Scanner 16

Accessories for the Scanner 17

More Information 19

Overview of the Sabre 1552 Scanner

The Intermec Sabre 1552 Scanner delivers quick, effortless bar code scanning. The following table lists the different scanner configurations, giving the optics and radio frequency (RF) configurations by country.

Scanner	Configuration
1552C0003	A standard-range optics scanner with RF for Europe, except France and Spain.
1552C0004	A standard-range optics scanner with RF for Argentina, Brazil, Canada, Chile, U.S.A.
1552C0007	A standard-range optics scanner with RF for Australia.
1552C0008	A standard-range optics scanner with RF for France, Mexico, and Spain.
1552C0103	An advanced long-range optics scanner with RF for Europe, except France and Spain.
1552C0104	An advanced long-range optics scanner with RF for Argentina, Brazil, Canada, Chile, U.S.A.
1552C0107	An advanced long-range optics scanner with RF for Australia.
1552C0108	An advanced long-range optics scanner with RF for France, Mexico, and Spain.
1552C0203	A long-range optics scanner with RF for Europe, except France and Spain.
1552C0204	A long-range optics scanner with RF for Argentina, Brazil, Canada, Chile, U.S.A.
1552C0207	A long-range optics scanner with RF for Australia.
1552C0208	A long-range optics scanner with RF for France, Mexico, and Spain.
1552C0403	A high-visibility optics scanner with RF for Europe, except France and Spain.
1552C0404	A high-visibility optics scanner with RF for Argentina, Brazil, Canada, Chile, U.S.A.

(Continued on next page)

Scanner Configurations (continued)

Scanner	Configuration
1552C0407	A high-visibility optics scanner with RF for Australia.
1552C0408	A high-visibility optics scanner with RF for France, Mexico, and Spain.
1552C0503	A high-density optics scanner with RF for Europe, except France and Spain.
1552C0504	A high-density optics scanner with RF for Argentina, Brazil, Canada, Chile, U.S.A.
1552C0507	A high-density optics scanner with RF for Australia.
1552C0508	A high-density optics scanner with RF for France, Mexico, and Spain.
1552C0603	A linear imager scanner with RF for Europe, except France and Spain.
1552C0604	A linear imager scanner with RF for Argentina, Brazil, Canada, Chile, U.S.A.
1552C0607	A linear imager scanner with RF for Australia.
1552C0608	A linear imager scanner with RF for France, Mexico, and Spain.

Configurations are continually being added to this list; consequently, some of the most recent additions may not be shown here. Contact your local Intermec representative for a current list.

Unpacking the Scanner

Your scanner was thoroughly tested and inspected before it was shipped from the factory. The shipping box contains:

- Sabre 1552 scanner
- *Sabre 1552 Bar Code Scanner User's Guide*
- Important 1552 Information manual supplement

If any of these items are missing or damaged, please contact your local Intermec representative. Retain the shipping box in case you need to ship the scanner.

Sabre 1552 Scanner

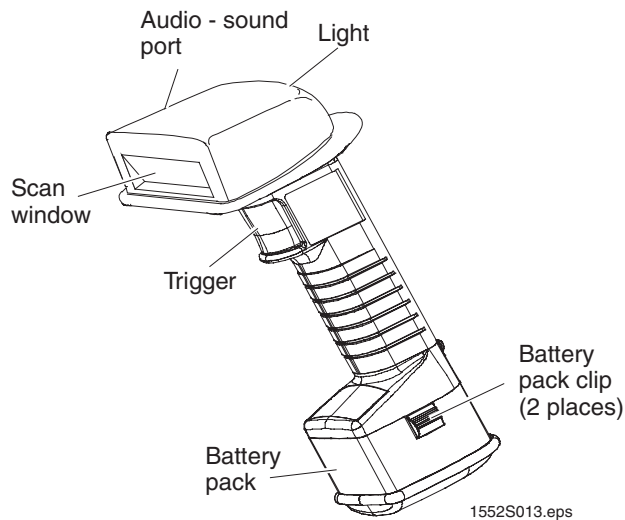

Understanding the Features

Please make sure that you understand these important features of the scanner.

Light

The light indicates the status of the scanner and battery pack.

Color	Description
Yellow	The device is scanning.
Flashing yellow	The battery pack charge is low. Remove the battery pack and recharge it.
Green	The scanner is out of range of the base station. Move the scanner and base to within 15 meters (50 feet) of each other.
Green for 2 seconds	The bar code has been successfully scanned and transmitted.
Green for 5 seconds	The scanner successfully scanned and transmitted a programming bar code.
Flashing green for 2 seconds	The scanner is out of the range of the base or not associated with the base.
Flashing green for 5 seconds	The scanner unsuccessfully scanned a programming bar code.
None	The device is not scanning.

Beeps

The scanner emits these beeps to indicate either a successful scan or a situation that requires your attention.

Beep Sequence	Description
No beep	No scanning, scanning, or low battery (trigger pulled)
1 beep	Successful decode and communication.
Clicking, then 1 beep	Successful reassociation.
Clicking only	Unsuccessful reassociation.
2 beeps, clicks, then 1 beep	Successful association to base.
3 beeps (same tone)	Unsuccessful association to base (10th scanner), out of range, or no network.
3 beeps (2 high and 1 low)	Enter/exit programming mode or successful association to base. Successful or unsuccessful parameter change in programming mode.
4 beeps (low, high, low, high tones)	Communication error: successful decode with possible unsuccessful communication to base. Check host to determine if data arrived properly.

Electrical Rating

The scanner electrical ratings are \approx 4,5 to 5,5V; 380 mA.

Associating the Scanner to the MicroBar 9745 Base Station

Before you start scanning, you must associate your scanner to the MicroBar 9745 Base Station that the scanner will be sending data to. The scanner can only communicate with one base at a time, but the base can communicate with more than one scanner. Any parameters, such as preambles or postambles, loaded onto the base will be loaded onto the scanners associated to it.

To associate the scanner to the base

1. Connect the base to your network. For help, see the *Sabre 1552 Scanner and MicroBar 9745 Base Station System Manual* (Part No. 070086).
2. Install the battery pack in the scanner. The scanner sounds a single beep. For help installing the battery pack, see the instruction sheet that came with your battery pack.
3. Scan the bar code on top of the base. The scanner will sound two beeps, clicks, and one beep.

Associating the Scanner to the Base

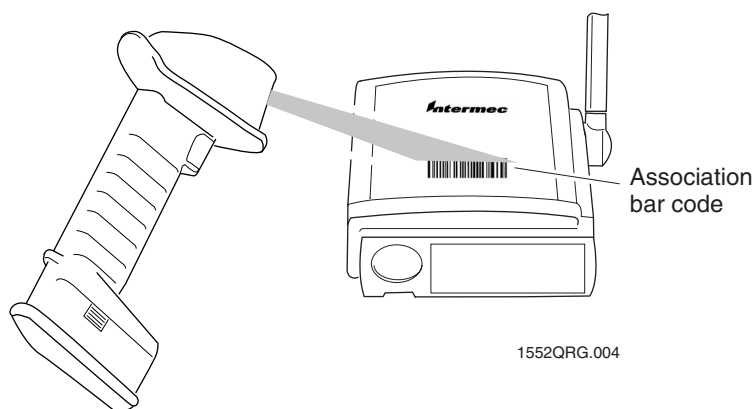

After a 3 to 4 second pause, the scanner will beep once and the green light on the base will flash. If the scanner beeps three times after 3 to 4 seconds, the scanner did not associate to the base. Make sure that there are no more than nine scanners associated to the base.

To enable you to associate the scanner when the base is out of reach, your base was provided with a second association label.

To improve RF communications, make sure that you follow the next requirements:

- When scanning, hold the scanner so that it is parallel to the antenna on the base.
- Mount the base so that nothing, particularly metal objects, obstructs the signal between the base and the scanners.

Operating the Scanner

Before you start scanning, make sure:

- The power to the reader/terminal, such as a 5050 vehicle-mount unit, is on.
- The scanner is associated to the base.
- All cable connections from the base station are secure.

To scan bar codes

1. Aim the scanner at a slight angle or pitch to the bar code and press the trigger. To help you center the scan beam on the correct bar code, you can configure the scanners with advanced long-range, long-range, or high-visibility optics to have a marker beam that appears before scanning when you pull the trigger.

Scanning Bar Codes

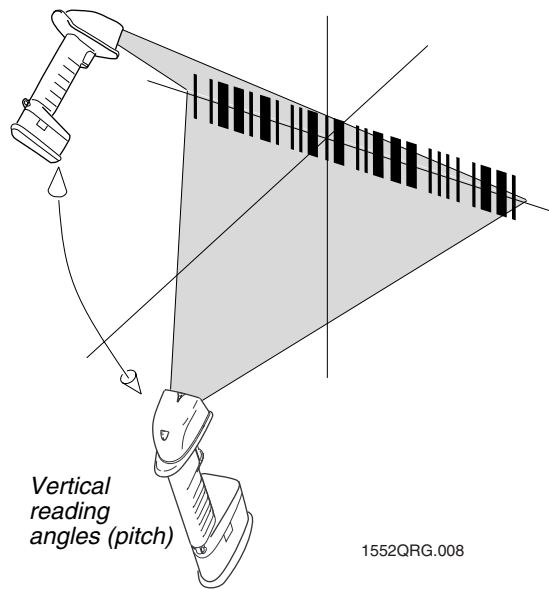

2. If you did not get a good read, adjust the scanner distance from the bar code and the position of the scan beam to make sure you scan every bar and space.



INCORRECT



CORRECT

155XQRG.006

3. When you get a successful read, the scan beam turns off, the scanner beeps twice (one beep for decoding the bar code and another for successful transmission to the base), and the light turns green.

Configuring the Marker Beam

You may want to configure a marker beam on advanced long-range, long-range, and high-visibility laser scanners.

To turn the marker beam off and on

- Scan one of the following bar codes.



Troubleshooting the Scanner

This table lists potential problems and their solutions.

Symptom	Solution
System is “jammed” and scanner will not operate.	The base could not process the information. Turn off the power to the reader/terminal, turn it on, and scan the association bar code on the base. The base will retain its configuration.
Scanner cannot read certain bar codes.	<p>The scanner was not set up to read this type of bar code symbology, or the bar code is damaged, covered up, or of poor quality.</p> <p>Scan another bar code on a similar item. If it scans, clean the bar code giving you trouble.</p> <p>If you are still unable to scan, make sure the bar code symbology you are scanning is enabled. For help, see the <i>Sabre 1552 Scanner and MicroBar 9745 Base Station System Manual</i>.</p>
Scanner does not read bar codes quickly and sometimes requires multiple scans.	<p>Try the following:</p> <ul style="list-style-type: none">• Clean the window with a cotton cloth moistened with an ammonia and water solution. Dry with a soft cotton cloth or allow to air dry.• Make sure the bar code is free of dirt and grime. Then scan at a slight angle or pitch to the bar code (see “Operating the Scanner” earlier in this guide).• Try adjusting the scanning distance.• Disable all bar code symbologies except for the bar code symbology you are scanning.• The scanner may be out of range of the base. Move the scanner and base to within 15 meters (50 feet) of each other.

Troubleshooting the Scanner (continued)

Symptom

Solution

Scanner does not read the correct uppercase or lowercase letter, or number and symbol.

If you use the Caps Lock on your reader/terminal, you must enable the Caps Lock command for the scanner to read and correctly decode bar code labels with uppercase letters.

If you use the Shift key on your reader/terminal, you must enable the Shift Lock command for the scanner to read and correctly decode bar code labels with symbols (for example: !#\$%).

Scanner does not read “shiny” bar codes.

Scan at a slight angle or pitch to the bar code (see “Operating the Scanner” earlier in this guide).

The green light is flashing and the scanner emits three beeps.

The scanner is not communicating with the base. Try the following to establish communication:

- Scan the association label on the base station.
- Make sure that nothing, particularly metal, is blocking the signal.
- Make sure your body is not blocking the signal.
- Move the scanner and base to within 15 meters (50 feet) of each other.
- Move the scanner so that it is parallel to the antenna on the base.

Scanner emits three beeps.

An error has occurred.

The scanner is not communicating with the base. Make sure that the scanner is in range and that the scanner is associated to the base.

The scanner does not recognize the programming bar code scanned. Make sure you are scanning the correct programming bar code and try again.

Troubleshooting the Scanner (continued)

Symptom	Solution
The yellow LED flashes when you pull the trigger.	The battery pack power is low. Remove the battery pack and charge it. For help, see the instruction sheet that came with the battery pack.
Scanner emits a continuous beep.	The scanner is out of range of the base. Move the scanner and base station to within 15 meters (50 feet) of each other.
Scanner does not emit a beam and does not operate.	The scanner is not receiving power. Make sure the battery pack is fully charged. Replace the battery pack if damaged.

If you continue to encounter problems with your scanner, contact your local Intermec representative.

Maintaining the Scanner

Water or grime on the window of the scanner will distort the scan beam and impair performance. Moving from one temperature extreme to another causes condensation to form on the optical surfaces that affects scanner performance.

- Clean the window with a cotton cloth moistened with an ammonia or water solution. Dry with a soft cotton cloth or allow to air dry.
- Do **not** use a dry tissue to wipe the window. This causes small scratches on the window that will gradually affect performance.
- Do **not** immerse the scanner in water.
- Operate and store the scanner and battery pack in an environment with 0% to 95% relative humidity.
- Operate the battery pack in temperatures within -20°C to 50°C (-4°F to 122°F) and store the battery pack in temperatures within -30°C to 60°C (-22°F to 140°F).

Accessories for the Scanner

These accessories are available for your scanner. To order an accessory, call your local Intermec representative.

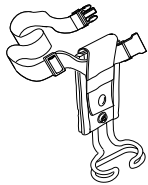

Holster and Belt Part No. 068174

You can store your scanner on you when it is not in use. The holster can be used with the belt provided or with any regular belt.



Wall-Mount Scanner Holder Part No. 068176

The wall-mount holder is a convenient way to store your scanner when it is not in use.

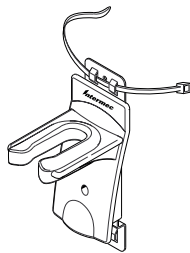

Vehicle-Mount Scanner Holder Part No. 068175

You can attach the vehicle-mount holder to a post or surface of a vehicle with tie-wraps and double-stick tape.

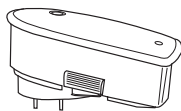

Nickel Metal Hydride (NiMH) Battery Pack Part No. 070066

The NiMH battery pack is a nominal 1200 mAh, 4.8 V battery pack with integral charger for your scanner.

1552QRG.007

Accessories (continued)

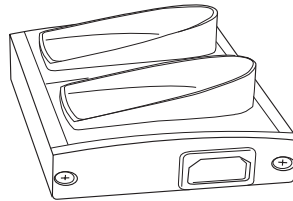

2-Bay Charge Strip

Part No. 067255

You can use the charge strip to charge two NiMH battery packs.

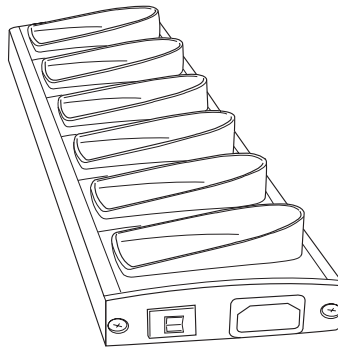

6-Bay Charge Strip

Part No. 067254

You can use the charge strip to charge six NiMH battery packs. The 6-bay charge strip also comes with a circuit breaker.

1552QRG.010

AC Power Cords for the Charge Strips

Country or Region	Part No.
Chile and Italy	586282
Denmark and Greenland	586283
Europe	586267
Liechtenstein and Switzerland	586276
North and Central America	586105
South Pacific	586281
United Kingdom	586266

More Information

You may need additional information when working with the Sabre 1552 Scanner in your data collection system. Please visit our Web site at www.intermec.com to download many of our current manuals in PDF format. To order printed versions of the Intermec manuals, contact your local Intermec representative.

Manual	Part No.
<i>Sabre 1552 Scanner and MicroBar 9745 Base Station System Manual</i> (covers all versions of the 1552 scanner)	070086



Corporate Headquarters
6001 36th Avenue West
Everett, Washington 98203
tel 425.348.2600
fax 425.355.9551
www.intermec.com

Sabre 1552 Bar Code Scanner User's Guide



067049-004